

REVISIE TABEL				
Rev.	Gewijz door	Datum	Wijzigingnr	Omschrijving

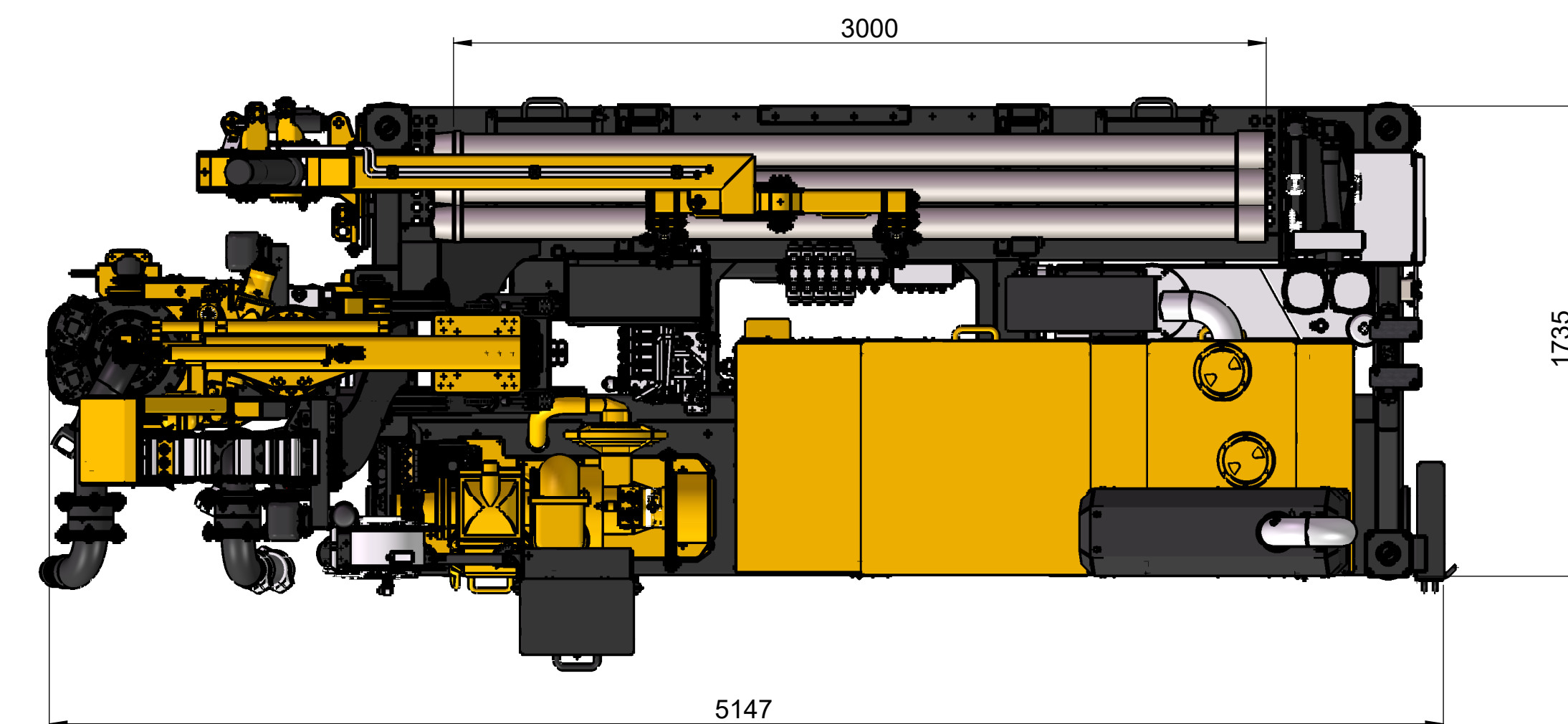
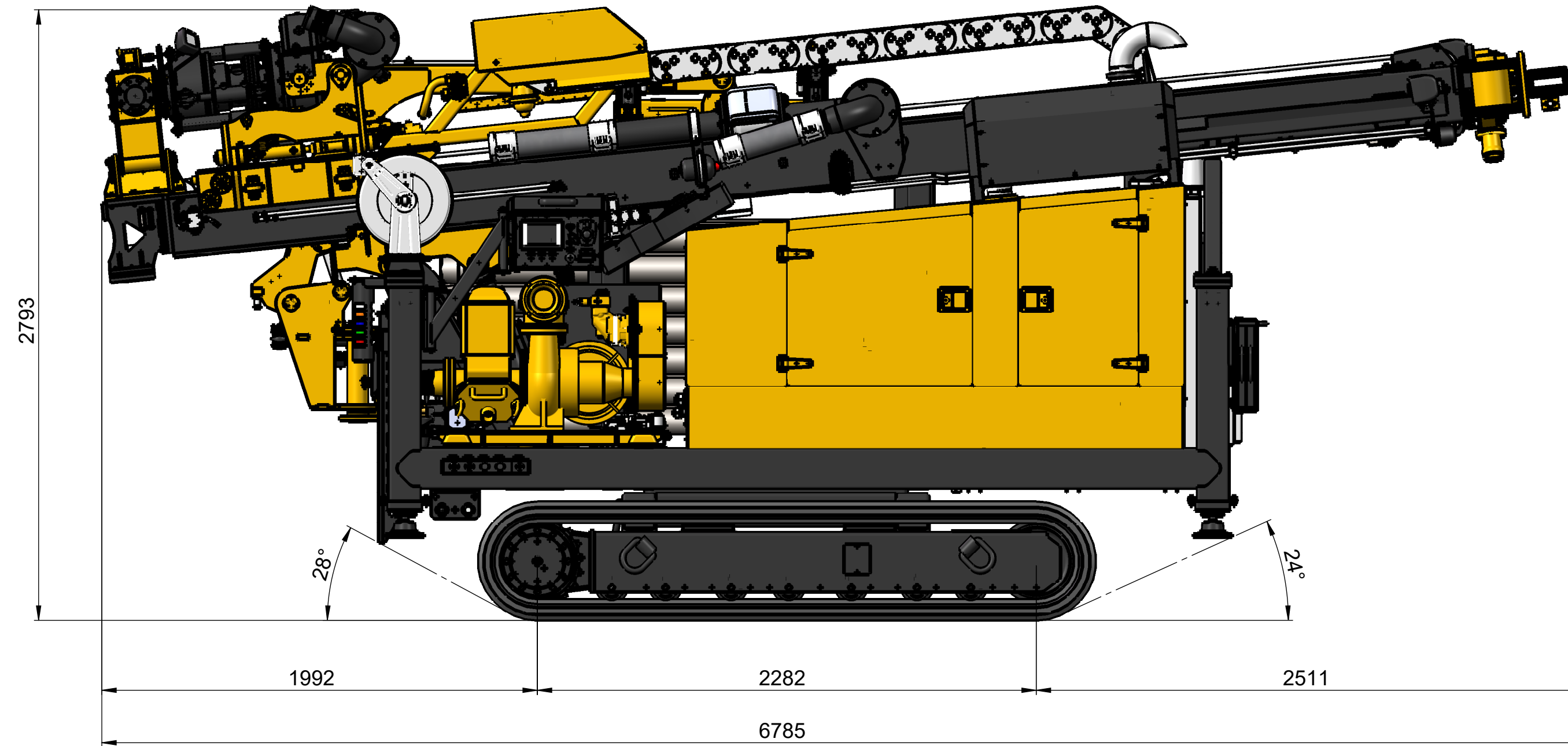
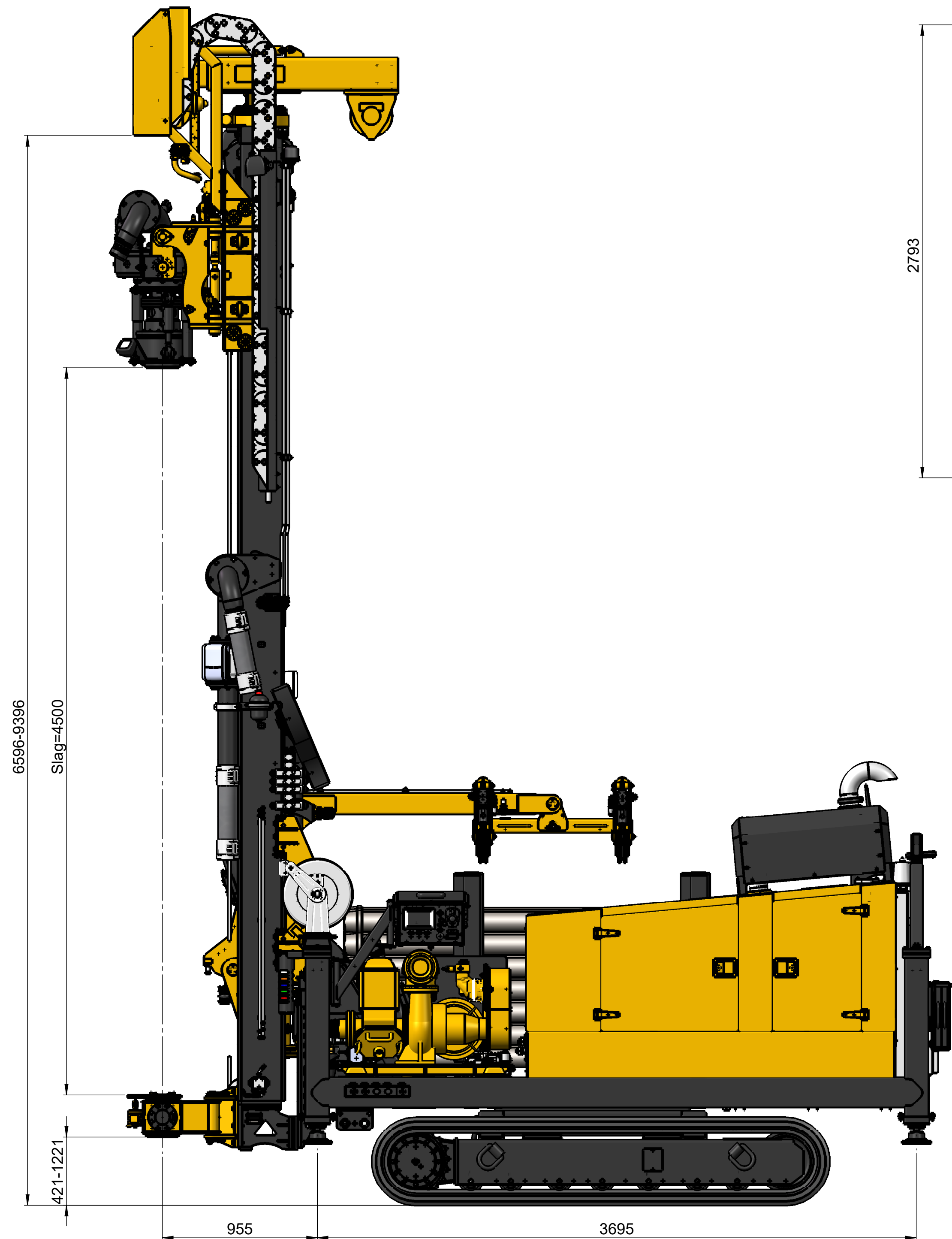

Ruwheid volgens NEN 3634	Maattoleranties volgens ISO-2768m	Vorm- en Plaattoleranties volgens ISO-2768k	Materiaal: Material <not specified>
	Schaal: 1:20	Getekend: K. Weerstand	Gecontroleerd:
	Maateenheid: mm	Datum Get: 29-09-2022	Datum Controle:
CONRAD <small>ALL RIGHTS RESERVED</small>		<small>CONRAD STANEN B.V. P.O. BOX 1064 NL 8300 BB EMMELOORD</small>	
		Tekeningnr 657078 Artikelnr	
Omschrijving: Boxer 150 B render			Blad 1 van 1